

Max.Sıcaklık / Max Temperature : -30+160°C
 Max.Basınç / Max. Pressure : 10bar
 Max.Hız / Max. Speed : 10m/s

Sabit yüzey : G4 -Silisyum,Karbon
 Stationary surface : G4-Silisyum,Carbon

O-ring Malzemesi : Viton,FKM,SİLİKON vs.
 O-ring Material : Viton,FKM,SİLİKON etc.

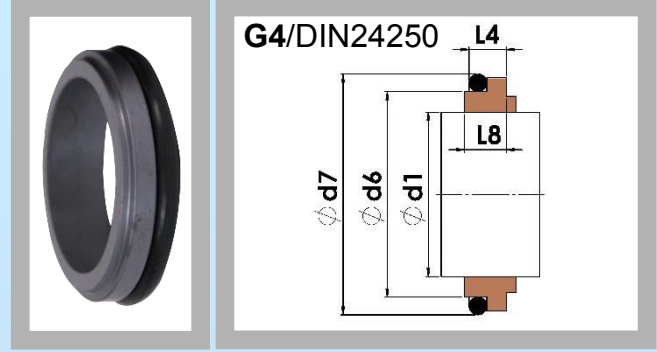

ÜRÜN AÇIKLAMASI / PRODUCT DESCRIPTION

Sabit yüzey seçenekleri (silisyum karbür,seramic vs..) sipariş esnasında satış ekibine bildirilmelidir.
Stationary face options (silisyum carbide,ceramics,etc.) should be pre-informed to our sales staff while placing an order .

MODEL	Mil çapı / Stem dia. Ød1	d6	d7	L4	L8
Duramech P-K 707 / NE7M x 10	10	15,5	19,2	6,6	7,5
Duramech P-K 707 / NE7M x 12	12	17,5	21,6	5,6	6,5
Duramech P-K 707 / NE7M x 14	14	20,5	24,6	5,6	6,5
Duramech P-K 707 / NE7M x 15	15	20,5	24,6	6,6	7,5
Duramech P-K 707 / NE7M x 16	16	22,0	28,0	7,5	8,5
Duramech P-K 707 / NE7M x 18	18	24,0	30,0	8,0	9,0
Duramech P-K 707 / NE7M x 20	20	29,5	35,0	7,5	8,5
Duramech P-K 707 / NE7M x 22	22	29,5	35,0	7,5	8,5
Duramech P-K 707 / NE7M x 24	24	32,0	38,0	7,5	8,5
Duramech P-K 707 / NE7M x 25	25	32,0	38,0	7,5	8,5
Duramech P-K 707 / NE7M x 26	26	34,0	40,0	8,0	9,0
Duramech P-K 707 / NE7M x 28	28	36,0	42,0	9,0	10,0
Duramech P-K 707 / NE7M x 30	30	39,2	45,0	10,5	11,5
Duramech P-K 707 / NE7M x 32	32	42,2	48,0	10,5	11,5
Duramech P-K 707 / NE7M x 33	33	44,2	50,0	11,0	12,0
Duramech P-K 707 / NE7M x 35	35	46,2	52,0	11,0	12,0
Duramech P-K 707 / NE7M x 38	38	49,2	55,0	10,3	11,3
Duramech P-K 707 / NE7M x 40	40	52,2	58,0	10,8	11,8
Duramech P-K 707 / NE7M x 42	42	53,3	62,0	12,0	13,2
Duramech P-K 707 / NE7M x 43	43	53,3	62,0	12,0	13,2
Duramech P-K 707 / NE7M x 45	45	55,3	64,0	11,6	12,8
Duramech P-K 707 / NE7M x 48	48	59,7	68,4	11,6	12,8
Duramech P-K 707 / NE7M x 50	50	60,8	69,3	11,6	12,8
Duramech P-K 707 / NE7M x 53	53	63,8	72,3	12,3	13,5
Duramech P-K 707 / NE7M x 55	55	66,5	75,4	13,3	14,5
Duramech P-K 707 / NE7M x 58	58	69,5	78,4	13,3	14,5
Duramech P-K 707 / NE7M x 60	60	71,5	80,4	13,3	14,5
Duramech P-K 707 / NE7M x 63	63	74,5	83,4	13,3	14,2
Duramech P-K 707 / NE7M x 65	65	76,5	85,4	13,0	14,2
Duramech P-K 707 / NE7M x 68	68	82,7	91,5	13,7	14,9
Duramech P-K 707 / NE7M x 70	70	83,0	92,0	13,0	14,2
Duramech P-K 707 / NE7M x 75	75	90,2	99,0	14,0	15,2
Duramech P-K 707 / NE7M x 80	80	95,2	104,0	15,0	16,2